

PRODUCT DATASHEET

KG700 KALM Shower Shelf

Part of the multi-award winning KALM Co-Produced Washroom Range, the KALM Shower Shelf is an anti-ligature storage solution developed specifically for secure mental health washrooms. This solution delivers high strength performance and has been ligature and durability tested to ensure it meets safety standards.

The KALM Shower Shelf has been carefully designed to ensure it supports the normal routines of service-users. Feedback from our co-production team was that shelves are normally either too small to hold their items, or so big they were reminded of their missing home comforts. The considered design means that it holds enough items, with an etched surface to ensure they remain securely in place. This, coupled with the softened geometry and concealed fixings, helps to create a calming, non-institutional environment to aid patient rehabilitation and recovery.



Installation Instructions

For installation guidance please visit:
kingswaygroupglobal.com/en-us/kg700-install

Operation and Maintenance

Operation

Provides practical storage for toiletries and washroom items while maintaining smooth anti ligature geometry.

Maintenance

Regular inspection is recommended to ensure the product remains secure and fit for purpose. Check for signs of damage, defects, tampering or abuse. Any compromised components should be replaced immediately.

Cleaning

Our preferred cleaning product for maintaining the appearance and performance of the polycarbonate surface is VuPlex plastic cleaner.

Alternatively clean using non abrasive neutral pH detergents diluted in warm water and applied with a soft cloth.

Avoid abrasive pads solvent based cleaners highly alkaline products or aggressive chemical agents to maintain long term integrity.

Testing and Warranty

Specification

Product: KG700 KALM Shower Shelf

Overall Dimensions: 306mm W x 120mm H x 80mm D

Material: antimicrobial impact-resistant polycarbonate

Testing

DHF TS001:2013

BS EN 356 Hard Body Impact

BS EN 596 Soft Body Impact

1 Year Manufacturer's Defect Warranty
covering faulty manufacture, not for damage

PRODUCT DIAGRAM

KG700 KALM Shower Shelf

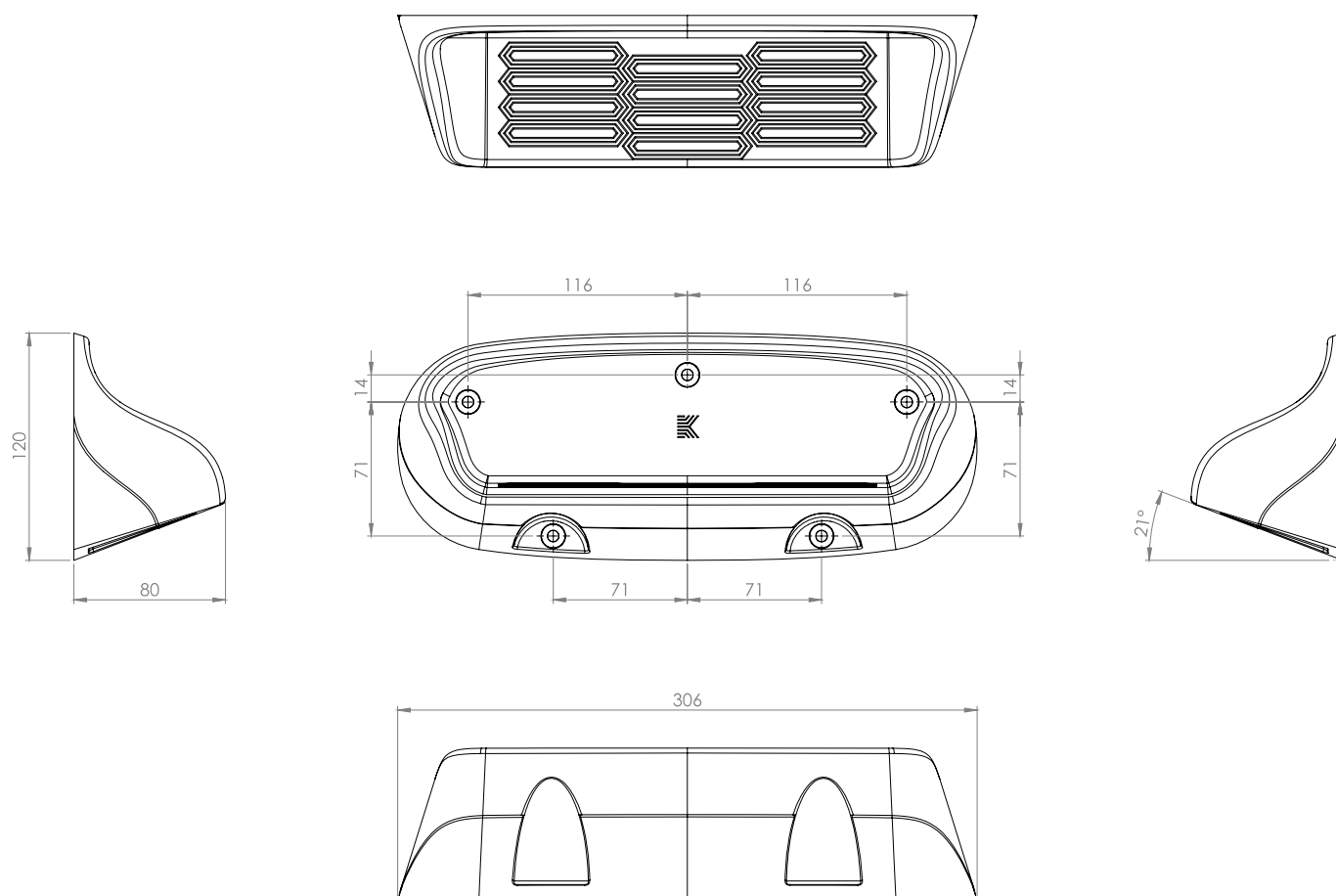

Terms and conditions:

To see our full terms and conditions, please visit: kingswaygroupglobal.com/en-us/terms