

PRODUCT DATASHEET

KG35 Double Action Transom Closer

The Double Action Transom Closer is a concealed unit that allows doors to open in both directions and automatically returns them to the closed position, providing a safe means of controlling double action doors. It is held securely in place by 6 anti-tamper fixings through the stainless steel cover plate.



Terms and conditions:

To see our full terms and conditions, please visit:
kingswaygroupglobal.com/en-au/terms

Your Partner in Patient Safety

Installation Description

The KG35 Double Action Transom Closer is only supplied as part of a Kingsway Group Complete Door System where all components are fitted and tested in the production process.

Operation and Maintenance

Operation

The transom closer has been designed to allow doors to open 90° in both directions. The closing force and the latching action can both be adjusted depending on the type of door it is and whether there are air pressure issues that need to be overcome, i.e. a small room without any ventilation will need more latching force to close the door due to the air pressure.

Maintenance

Periodic checks should be made to the closer to ensure the closing and latching action is correct for the door type. Checks should also be made for signs of tampering and damage. Cleaning of the closer should be done only with a damp cloth and mild detergent where necessary. Excess use of liquid will affect the action of the closer and make void the guarantee.

Warranty

1 Year Manufacturer's Defect Warranty*

*For faulty manufacture and not for damage

Specification

KG35 Double Action Transom Closer

PRODUCT DIAGRAM

KG35 Double Action Transom Closer

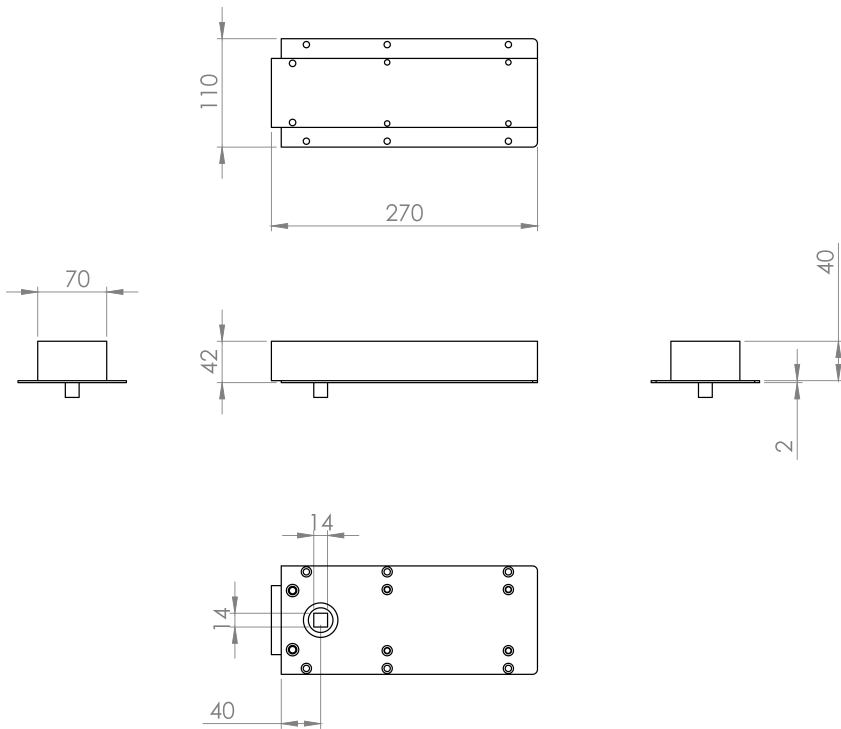

- 1 = Spur-cut spindle
- 2 = Closing force adjustment
- 3 = Setting hold-open device / delayed closing action
- 4 = Closing speed adjustment
- 5 = Latching action adjustment

Single action door	.
Double action door	.
Door weight (up to)	150 kg
Leaf width (up to)	1100 mm
EN Size	1-4
Adjustable closing speed	.
Closing range from	175"
Adjustable closing force	.
Adjustable latching action	.



Terms and conditions:

To see our full terms and conditions, please visit: kingswaygroupglobal.com/en-au/terms