

PRODUCT DATASHEET

KG164 Safe Serve Tray Hatch With 3-Point Lock

The KG164 Secure Tray Hatch is a high-secure, auto-locking unit that is installed into doors to reduce patient and staff safety risks. It allows items up to 14" wide to be passed into a room, removing the need to open the door for communication or patient serving. The unit is secured with security bolts on the staff side, with no visible screws on the patient side.



Terms and conditions:

To see our full terms and conditions, please visit:
kingswaygroupglobal.com/en-us/terms

Installation Description

- Cut out the required aperture to suit the unit
- Attach the inner part of the food hatch and make sure that it is level
- Attach the front fascia and ensure that all screws are tight

Operation and Maintenance

Operation

Unlock the hatch using the Kingsway Staff Key and pull the handle to swing the tray down into the open position. To close the hatch, push the tray into the closed position using the handle and ensure the auto-locking latch engages.

Maintenance

Light lubricant can be used on moving parts and periodic checks should be made to ensure the locks operate smoothly.

Cleaning

The hatch can be cleaned using standard commercial detergents and cleaners but care should be taken to avoid cleaning with abrasive cloths which will scratch the surfaces of the unit.

Warranty

1 Year Manufacturer's Defect Warranty*

*For faulty manufacture and not for damage

Specification

KG164 Secure Tray Hatch With 3-Point
Locks 1 3/4"

PRODUCT DIAGRAM

KG164 Safe Serve Tray Hatch With 3-Point Lock

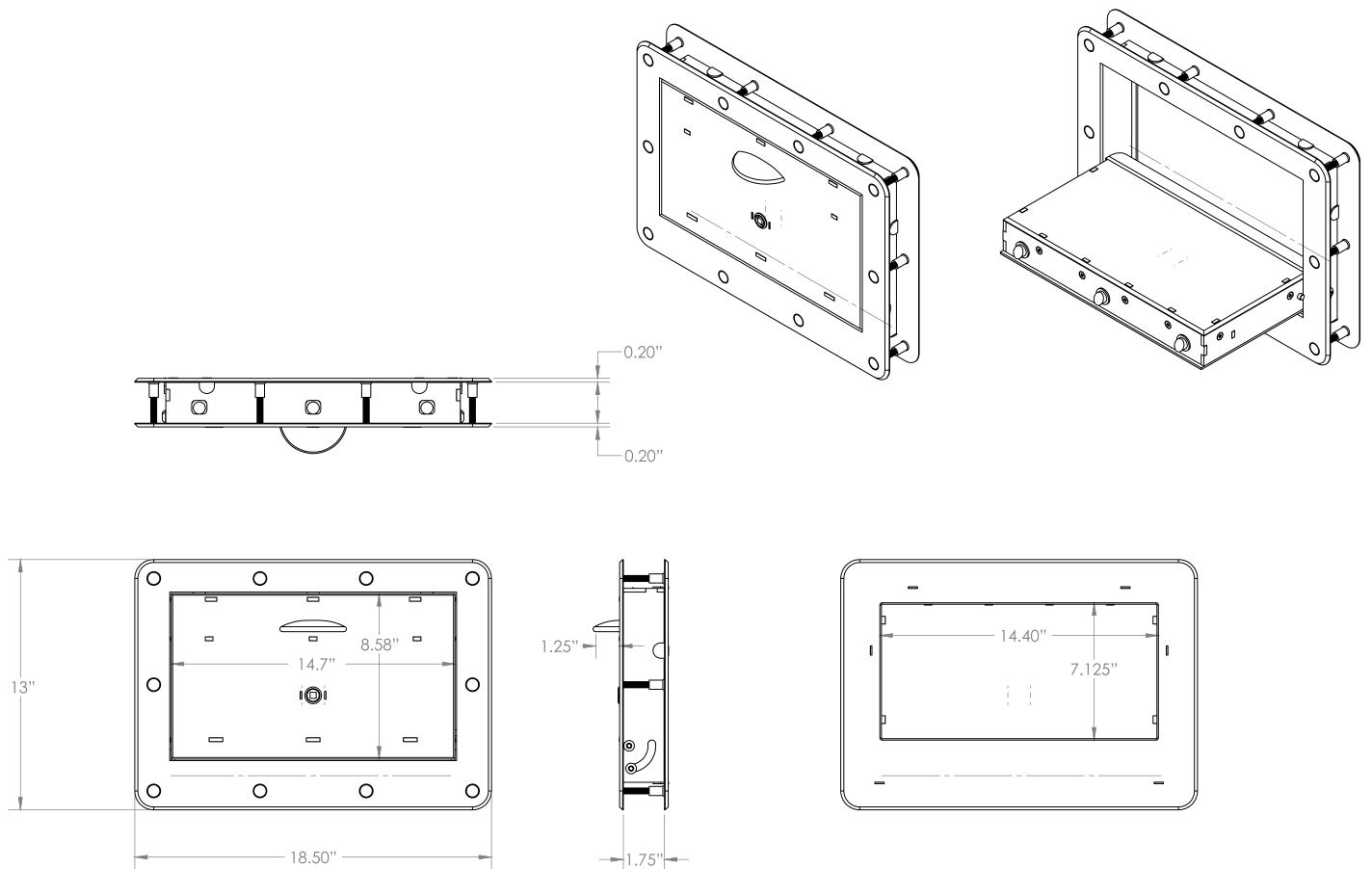

Terms and conditions:

To see our full terms and conditions, please visit: kingswaygroupglobal.com/en-us/terms